



## PRECISION ABRASIVE WATERJET ACCESSORIES

### Accessory Specifications

## Weir

### Standard Features

- Provides extended filter life in Closed Loop Systems
- All internal plates can be removed for easy clean out
- Two standard ports allow drainage
- Rust inhibiting epoxy finish
- 2' x 4' footprint
- 135-gallon functional capacity constructed from 10-gage steel

### System Specifications

Height	38"
Width	25"
Length	39"
Inlet	1-1/2" NPT
Outlet	1-1/2" NPT
Clean-Out	1" NPT
Max. Capacity	154 gallon
Dry Weight	230 lb

*Specifications subject to change.*

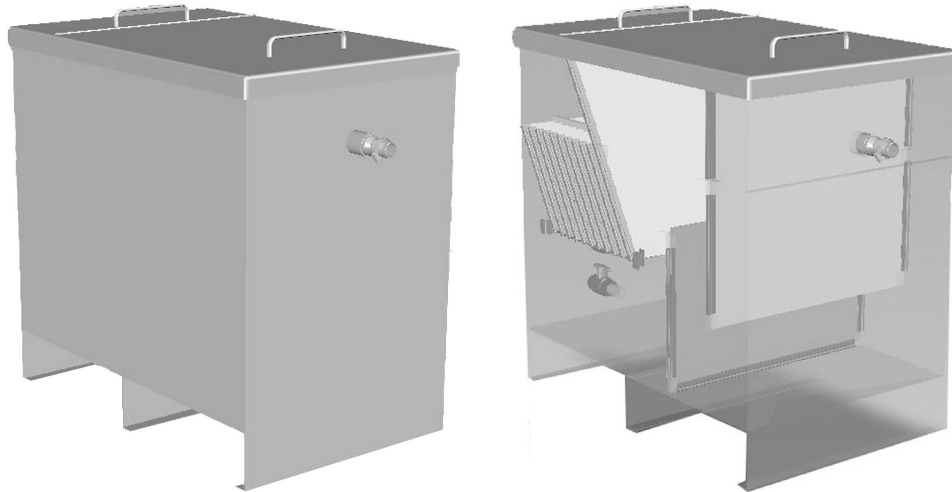

## Settling Weir System

The Settling Weir System removes suspended solid particles from waste water.

The OMAX® Settling Weir combines an under-over baffle along with a laminar flow clarifier to maximize the settling time for solids exiting the OMAX Catcher Tank. The system has been designed so that it can be easily cleaned out by a variety of methods. The unit can be shoveled out or pumped out using a diaphragm or sump pump.

# WEIR

### About OMAX

OMAX has the industry leading patented abrasivejet controller with a built-in expert system. Our exclusive "Compute First-Move Later" motion control system automates most programming and tool setup work, virtually eliminating the need for extensive operator training. Plus, with free OMAX Intelli-MAX® Software upgrades for the life of the machine and our ongoing commitment to advance the efficiency of our technology and software, OMAX saves you time and money.



### WORK SMART



The OMAX Technology Guarantee entitles you, as the original owner, to free OMAX software upgrades for the life of the machine.

### OMAX Corporation

21409 72nd Ave South, Kent, WA 98032  
253-872-2300 **tel** 253-872-6190 **fax**  
1-800-838-0343 **toll-free**  
**WWW.OMAX.COM website**

Printed in the U.S.A © August 2008 All rights reserved. S-0023