

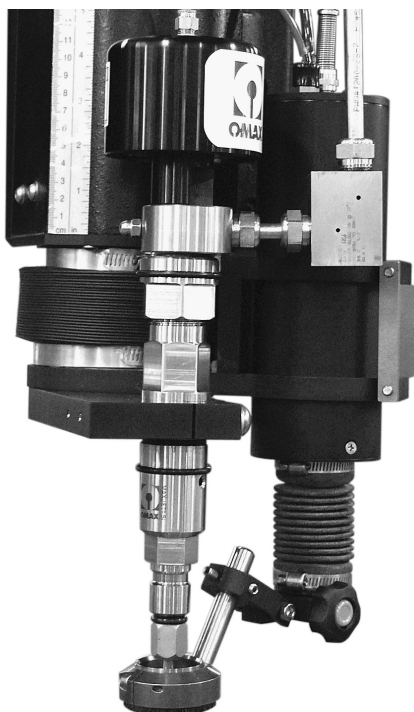

PRECISION ABRASIVE WATERJET ACCESSORIES



Shown on the Motorized Z-Axis

OMAX® Collision Sensing Terrain Follower

The OMAX Collision Sensing Terrain Follower allows a JetMachining® Center to automatically and accurately cut parts from materials with irregular or warped surfaces without the need for special programming.

The Terrain Follower attaches directly to the machine's Z-axis. Changes in a material's height are detected and the Z-axis automatically makes the required height adjustments, maintaining the necessary cutting standoff (typically within $\pm 0.020''$). A collision detector pauses jet motion if obstructions are in the path of the nozzle.

CSTF

Accessory Specifications

CSTF

Standard Features

- Linear encoder senses changes in material height during cutting operations
- A collision detector protects the nozzle and related hardware from damage
- Built-in containment guard minimizes nozzle splash and spray during machining
- Easy field retrofit to a Motorized Z-Axis or Tilt-A-Jet®
- Heavy duty liquid-tight electrical fitting with spring-type strain relief
- O-ring seal bulk-head air fittings with protective boots

Benefits

- Automatically maintains the correct nozzle standoff throughout the cutting process
- Adjusts automatically to uneven surfaces; reduces need for additional programming
- Constantly senses necessary height adjustments when activated, unlike other contour following products on the market
- Reduces potential equipment damage from nozzle collisions
- Simple setup and operation
- No special programming required
- No requirement to map the elevation of your material—simply move the nozzle to where you want to begin cutting and push start
- Electrical connections armored for durability
- Robust sealing to withstand the abrasive waterjet environment
- No matter where you are located in the world, you'll receive effective technical support to ensure your CSTF is operating at its highest levels. With hundreds of active units in the field, our technicians are strategically located to meet customer needs.



The OMAX Technology Guarantee entitles you, as the original owner, to free OMAX software upgrades for the life of the machine.

OMAX Collision Sensing Terrain Follower

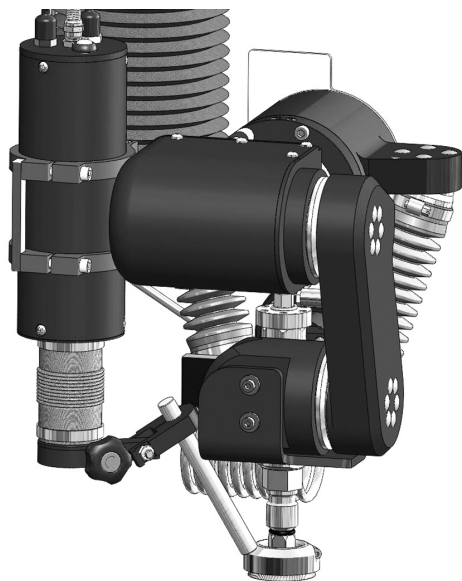

Shown on the Tilt-A-Jet

Requirements

- Microsoft Windows®
Contact OMAX Customer Service for information if you are running DOS
- Motorized Z-Axis or Tilt-A-Jet
- OMAX Software version 11 or greater

May experience reduction in travel with OMAX Models 55100, 5555, 2652, and 2626. Contact OMAX for more information.

About OMAX

OMAX has the industry leading patented abrasivejet controller with a built-in expert system. Our exclusive "Compute First-Move Later" motion control system automates most programming and tool setup work, virtually eliminating the need for extensive operator training. Plus, with free OMAX Intelli-MAX® Software upgrades for the life of the machine and our ongoing commitment to advance the efficiency of our technology and software, OMAX saves you time and money.

For information on what other OMAX products and accessories can do for you, call us today at 800-838-0343 or visit our website at www.omax.com.

Best Applications

- Great for large sheets of nested parts
- Great for materials that stress relieve while cutting
- Ideal for cutting large parts on uneven or warped sheets
- Assists in cutting hard, smooth, or non-cosmetic surfaces

Improvements

- Offers a more robust sensing mechanism
- Equipped with more stable sensor mounting
- Auto-disables during machine shutdown
- Foot is more rigid and easily removed without tools

Note: Specifications subject to change without notice.



OMAX

**WORK
SMART**

OMAX Corporation

21409 72nd Ave South, Kent, WA 98032

253-872-2300 **tel** 253-872-6190 **fax**

1-800-838-0343 **toll-free**

WWW.OMAX.COM website

Printed in the U.S.A. © October 2010 All rights reserved. S-0030